



Operating Microscope OM-6

Serving Your Vision



Operating Microscope

OM-6

Versatile entry-level operating microscope ideal for out-patient procedures



TAKAGI has been serving the vision of the global eye-care industry since 1955.

TAKAGI brand products are developed, designed and manufactured in Nagano, a region famed for its thriving precision manufacturing industry. Protecting eye health means protecting opportunities to see the beautiful things in the world. It is based on this belief that we take great joy and pride in making our instruments beautiful as well as functional. Our world-class technological capabilities, assured quality and outstanding service, make us trusted by ophthalmic professionals in more than 80 countries worldwide.

TAKAGI's operating microscopes have achieved clear resolution through a process of development focused on "visibility" and by leveraging their optical performance. In addition to a wide and bright field of view, light intensity can be adjusted to suit each particular case and the surgeon's own preference, and the interface is intuitive and easy to use.

With its full range of basic functions, the OM-6 Operating Microscope provides standard level brightness and clarity of view. This simple, high-performance microscope combines outstanding operability and safety, and is optimised for ease of use in a variety of out-patient procedures, including on the eyelids, conjunctiva, cornea, and tear ducts. Thanks to its high-quality optical system it can also be used for cataract surgery, depending on the hospital/clinic environment.

Using an LED light source with an operating life of approximately 40,000 hours reduces the need for bulb changes and keeps power consumption low, ensuring a high degree of cost performance.

* LED operating life is defined as a state when light intensity drops to 70%.

The operating life of the LED used in OM-6 is approximately 40,000 hours, although this is not guaranteed.

Widefield eyepieces ensure brightness and ease of visibility

The three-step magnification, widefield eyepiece provides a bright and wide field of view of 48 mm / 28.8 mm / 18 mm in diameter, helping to facilitate out-patient procedures.

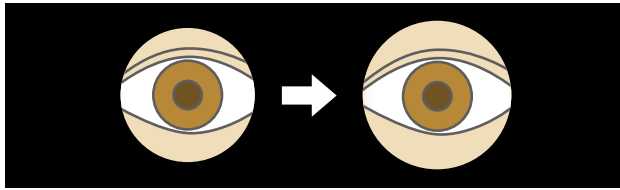

Before use of widefield eyepiece
Field of view: Ø26 mm
(at 1.0x magnification)

With OM-6 widefield eyepiece
Field of view: Ø28.8 mm
(at 1.0x magnification)

Deep depth of focus and wide field of view

The F = 200 mm objective lens has a deep depth of focus, enabling the microscope to focus over a wide area, eliminating the need for frequent focus adjustments.

The synergistic effect of the ergonomically designed binocular tubes inclined at a 45° angle further enhances comfort.

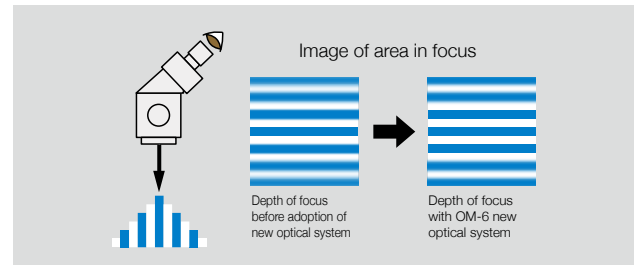

Variety of filters

Built-in heat-absorbing and blue correction filters prevent adverse effects on the patient's eyes due to LED heat and blue light. The blue filter helps to observe corneal abnormalities using fluorescein. When observing blood vessels, using a green (red-free) filter provides a clear contrast. The filter switching knob makes it easy to switch between each filter.



Direct LED illumination

The illumination system, developed for out-patient procedures, uses direct illumination with high-intensity LEDs.

Light intensity can be easily adjusted using the control panel, helping to expedite out-patient procedures.



High-grade class arm

The inclined arm shape provides more space under the arm, ensuring a safe and comfortable operating environment. The swivel locks on the microscope, balance arm, and support arm can be used to hold the microscope in the proper position for safe and secure surgery. It can also be folded away compactly for safe transportation.



Waterproof and dustproof foot controller for most frequently used functions.

An easy-to-operate foot controller is provided for the most frequently used focus adjustment functions. With an ergonomically optimised incline the foot controller is easy to operate, and the user can focus on procedures.

With a waterproof and dustproof rating of IPX6, the foot controller is resilient to liquids and cleaning materials.



Rich variety of options

A wide variety of space-saving options are available that take into account the out-patient environment. When connected using the Connecting Arm (U21-02) to the Full Reclining Chair (UN-21), procedures can be conducted in a limited-space environment.



If the base is switched for a flat base (O01-19) it is possible to install the microscope flush to the wall, and the base can be placed under a bed, enabling safe and comfortable procedures and operations even in confined spaces.



O08-21 + S11-02 TV camera adapter

By mounting a camera and connecting to a monitor it is possible to share with other medical staff and also record images of procedures and operations.

* Use with commercially available camera, monitor and recorder.



DIS1 Digital imaging system

By connecting the camera-equipped DIS1 to a monitor, images of procedures and operations can be shared with other medical staff and also be recorded.

* Use with commercially available monitor and recorder.



O06-31SE Assistant microscope

This microscope for assistants provides a natural, bright image with a three-dimensional effect.



S01-14SE + O07-17 Inclined coupling

Attaching an inclined coupling enables backwards/forward and left/right movement.

Specifications

Model name	OM-6 Operating Microscope	
Microscope	Magnification changer	3 step manual magnification
	Objective lens	F = 200 mm
	Eyepieces	12.5x (high-eyepoint & wide-field)
	Field of view (diameter)	48, 28.8, 18 mm
	Binocular tube	45° inclined binocular tubes F = 125 mm
	Total magnifications	4.7x, 7.8x, 12.5x
	Focus (motorised)	30 mm
Illumination	Method	Direct illumination
	Light intensity adjustment	9 steps (5 level display on gauge)
	Light source	LED
	Illuminated field (diameter)	55 mm
	Filters	Heat-absorbing / Blue correction / Blue / Green (red-free)
Arm & Base	Type	Floor stand with 4 casters and 2 stoppers
	Balance arm stroke	400 mm (vertical)
	Maximum arm reach	1045 mm
	Maximum load tolerance on arm	Up to 2.4 kg of accessories
	Control panel	Brightness display, light intensity control, illumination ON/OFF switch, power switch
	Foot controller	Wired with focus control, IPX6 waterproof and dustproof performance
Others	Weight (excl. options)	62.3 kg
	Power input	70 VA
	Power supply	AC 100-230 V, 50/60 Hz
	Electrical protection class	Class 1

Dimensions

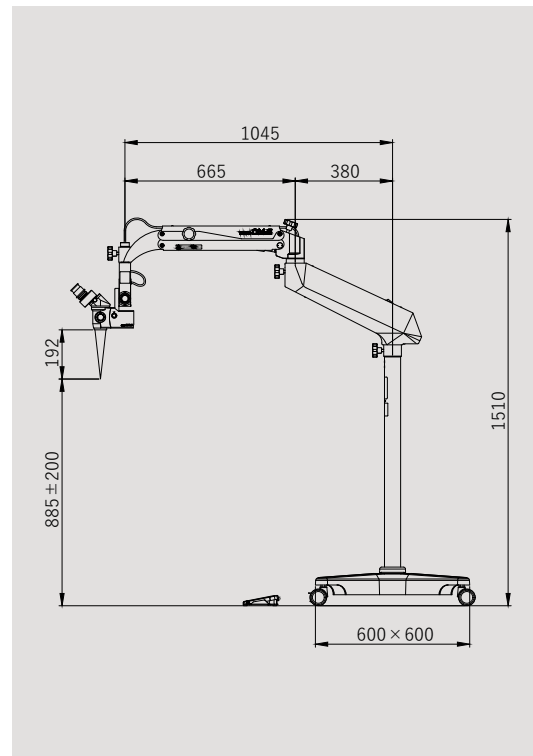

System Chart

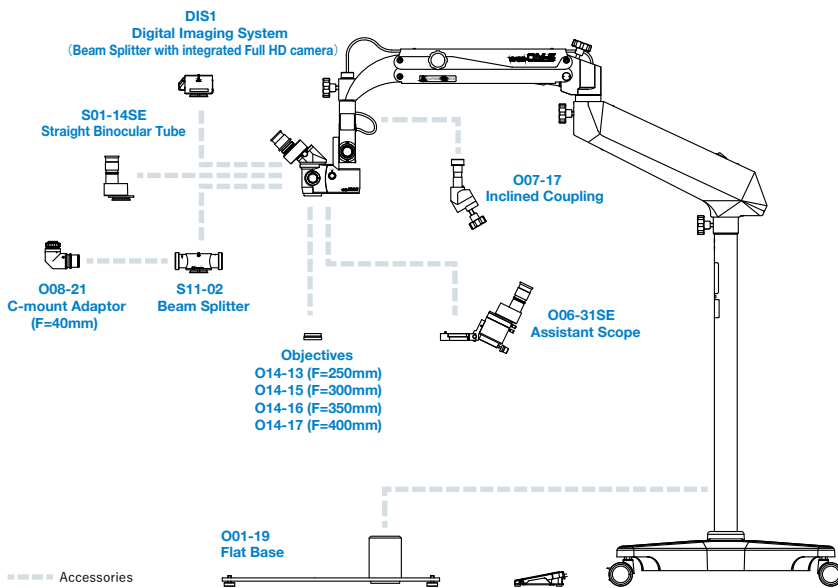

Accessories

Model number	Detailed information
DIS1	Beam splitter with built-in camera (possible to view images by connecting to a monitor)
O01-19	Flat base for wall side installation
O06-31SE	Assistant microscope capable of binocular stereoscopic viewing at 26° to the main microscope
O07-17	Inclined rotatable coupling
O08-21	TV camera mounting adapter with C-mount F = 40 mm
O14-13	Objective lens F = 250
O14-15	Objective lens F = 300
O14-16	Objective lens F = 350
O14-17	Objective lens F = 400
S01-14SE	Straight binocular tube for using a surgical microscope
S11-02	Beam splitter for mounting a camera (spectroscopic ratio 30 : 70)

To ensure safe and correct handling please read the user manual before using.

- Description and appearance as detailed in this brochure may be subject to change as improvements are made to products.
- Colours as they appear in brochure photographs may be slightly different to actual products due to lighting conditions when photographs were taken, or print colours.



For The Americas, Asia-Pacific & Middle East

Takagi Seiko Co., Ltd

330-2 Iwafune, Nakano-shi, Nagano-ken, 383-8585, Japan

TEL : +81(0)269-22-4511(Switchboard) URL : <https://www.takagi-j.com>



Your local distributor



For Europe & Africa

Takagi Ophthalmic Instruments Europe Ltd

Citylabs 1.0, Nelson Street, Manchester, M13 9NQ, UK

TEL : +44 (0)161 273 6330 URL : <https://www.takagi-europe.com>